

Shower and Bath

Crystal

Comfort, hygiene and safety for perfect patient and personal care

Electric or hydraulic shower stretcher

REF. 3860.00 / 3800.00



A shower stretcher that combines speed and silence, featuring a mattress designed for optimised washing and an adjustable headrest. Comfort, hygiene and safety for perfect patient and personal care.

REVAL
LE BIEN-ÊTRE DURABLE

REVAL
LE BIEN-ÊTRE DURABLE

Shower and Bath

Crystal

UNIQUE FEATURES

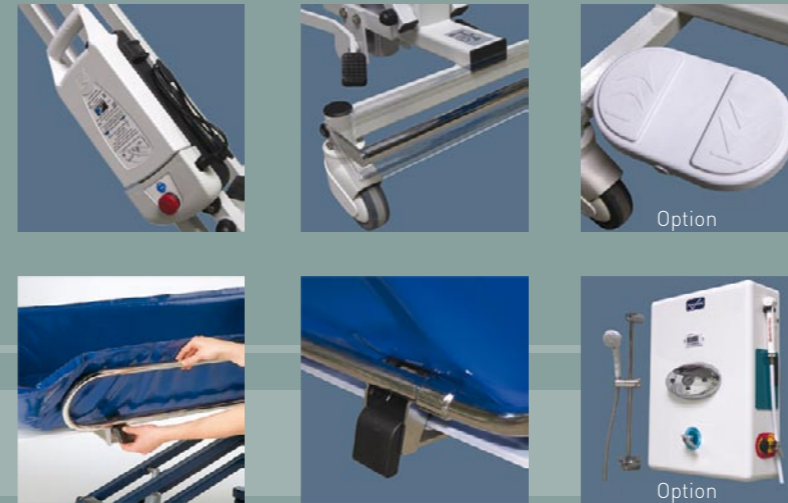

- The patient's comfort is ensured by the texture of the mattress
- The triangular headrest can adjust to any position
- Stainless steel side rails ensure the patient's safety

Available in electric or hydraulic models; in standard, elongated or child-sized versions

Electric or hydraulic shower stretcher

REF. 3860.00 / 3800.00

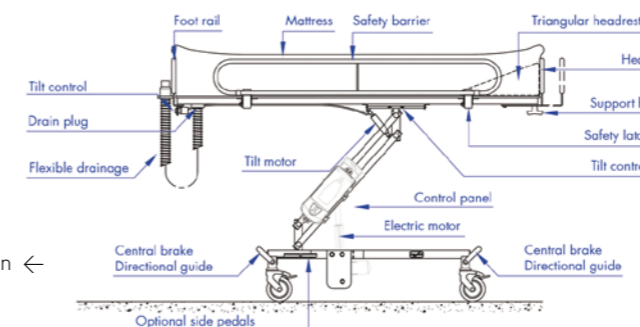
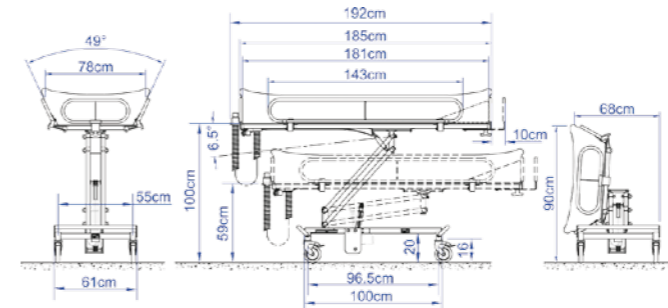

3860.00 Version ←

Safety standards

- 93/42/CEE (Medical equipment directive)
- NF EN 12182 (Technical support systems for handicapped persons)
- NF EN 1441 (Risk analysis for medical equipment)

Stretcher

- White, polypropylene (unbreakable) stretch
- Stretcher fold down for easy storage or cleaning
- Gas-powered tilt function motor with manual control
- Lateral barrier in stainless steel, outfitted with automatic safety locks
- Stainless steel foot rail
- Stainless steel head rail, adjustable over 10 cm
- Stretcher protection

Mattress

- Water-proof mattress built for intensive use, in soft PVC
- Central drain hole near feet
- Flexible drain pipe measuring 40 mm in diameter
- Triangular headrest

Hydraulic - 3 models

- 3800.00 - standard length (192 cm)
- 3801.00 - extra long (202 cm)
- 3800.20 - child-sized

Specifications

- Variable height (stretcher): 56 cm to 100 cm
- Stretcher tilt range: From 0° to 6.5°
- Maximum patient weight: 160 Kg
- Weight of shower stretcher: 65 Kg (Electric: 70 Kg)
- Electric version
- Capacity at fully charged: 40 lifts at 130 Kg
- 24V CC battery, 2,9 Ah, power: 10 A at 24V C.C.

REVAL - ZA Fief des Prises - Usseau 17220 Ste Soulle / La Rochelle - Tél. +33 (0)5 46 42 04 16 - www.groupe-reval.com